



Installation, Operation & Maintenance Instructions

750°C Recirculating Air Furnace
types ARF 7/22, ARF 7/45

This manual is for the guidance of operators of the above Lenton products and should be read before the furnace is connected to the electricity supply.

CONTENTS

Section		page
1.0	Symbols & Warnings	2
2.0	Installation	2
3.0	Operation	4
4.0	Maintenance	5
5.0	Repairs & Replacements	6
6.0	Fault Analysis	8
7.0	Circuit Diagrams	9
8.0	Fuses & Power Settings	11
9.0	Specifications	12

Manuals are supplied separately for the furnace controller (and overtemperature controller when fitted).

Please read the controller manuals before operating the furnace.

1.0 SYMBOLS & WARNINGS

1.1 Switches and Lights



Supply Light: when the furnace is connected to the electrical supply the light in the adjacent switch glows



Heat Light: the adjacent light glows or flashes to indicate that power is being supplied to the elements

1.2 Warning Symbols

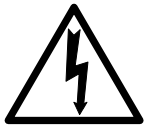

DANGER of electrical shock– read any warning printed by this symbol.



DANGER – hot surface. Read any warning printed by this symbol.
WARNING: all surfaces of a furnace may be hot.



DANGER – read any warning printed by this symbol.

2.0 INSTALLATION

2.1 Unpacking & Handling

When unpacking or moving the furnace always lift it by its base. Never lift it by the door. Use two people to carry the furnace where possible.

Remove any packing material from the door gear and furnace chamber before use.

2.2 Siting & Setting Up

Place the furnace in a well ventilated room, away from other sources of heat, and on a surface which is resistant to accidental spillage of hot materials. Do not mount the furnace on an inflammable surface.

Ensure that there is free space around the furnace. Do not obstruct any of the vents in the control section: they are needed to keep the controls cool. Keep a space of 50mm free at the back of the furnace behind the circulating fan.

Ensure that the furnace is placed in such a way that it can be quickly switched off or disconnected from the electrical supply - see below.

If the optional chimney is supplied, then fit it into the hole in the top of the furnace case. If the furnace is to be used to heat substances which emit fumes, then a fume extraction duct of about 150mm inlet diameter may be placed directly above the chimney outlet. Do not make a sealed connection to the furnace chimney as this causes excessive airflow through the chamber and gives poor temperature uniformity.

2.3 Electrical Connections

Connection by a qualified electrician is recommended.

Model ARF 7/22 is designed for use on a single phase A.C. supply, which may be Live to Neutral non-reversible, Live to Neutral reversible or Live to Live. Model ARF 7/45 may be supplied single phase or 3-phase (star or delta).

Check the furnace rating label before connection. The supply voltage should agree with the voltage on the label, and that the supply capacity should be sufficient for the amperage on the label.

The supply should be fused at the next size equal to or higher than the amperage on the label. A table of the most common ratings is also given in section 8.1 of this manual. Where a supply cable is present there are internal supply fuses; customer fusing is preferred but not essential.

Furnace with supply cable: either wire directly to an isolator or fitted with a line plug.

Furnace without supply cable: a permanent connection to a fused and isolated supply should be made to the internal terminals after temporary removal of the furnace back panel.

Connection by line plug: the plug should be within reach of the operator, and should be quickly removable.

Connection to isolating switch: this should operate on both conductors (single phase) or on all live conductors (three phase), and should be within reach of the operator.

The supply MUST incorporate an earth (ground).

CONNECTION DETAILS			<i>supply type</i>	
Supply	Terminal label	Cable colour	<i>Live-Neutral</i>	<i>Reversible or Live-Live</i>
1-phase	L	Brown	To live	to either power conductor
	N	Blue	To neutral	to the other power conductor
	PE	Green/Yellow	To earth (ground)	to earth (ground)
supply	Terminal label	Cable colour		
3-phase	L1	Black	to phase 1	
	L2	Black	to phase 2	
	L3	Black	to phase 3	
	N	Light Blue	to neutral <i>except delta</i>	
	PE	Green/Yellow	to earth (ground)	

2.4 “Universal Wiring”

ARF 7/45 when ordered 3-phase: 2003 onwards.

If the ARF 7/45 model is ordered for a 3-phase supply, it can be easily rewired between 1-phase and 3-phase supplies. This applies to 3-phase+N and 3-phase delta in the ranges 380/220V–415/240V and 208-240V, but does not apply to 3-phase star without neutral (e.g 380V).

To alter the configuration, remove the back panel and alter the wiring connections between the supply terminal block and the EMC filters, using the appropriate diagram from section 7.3.

Models made for single phase only and models before 2003 are not affected and cannot be converted to 3-phase.

If in doubt, please consult Carbolite.

3.0 OPERATION

The instructions for operating the temperature controller are given in a separate manual.

If the furnace is fitted with a time switch, see also the supplementary manual LS03.

If cascade control is fitted, see the supplementary manual LS07.

3.1 Operating Cycle

The furnace is fitted with a combined Supply light and Instrument switch. The light is on whenever the furnace is connected to the supply. The switch cuts off power to the control circuit.

Units made before late 2003. In these furnaces the Instrument switch does not cut power to the fan. The fan is on whenever furnace is connected to the supply. See section 7.1.

Connect the furnace to the electrical supply. The Supply light should glow.

Operate the instrument switch to activate the temperature controller. The controller becomes illuminated and goes through a short test cycle.

Adjust the temperature – see the controller manual.

Overtemperature option only. If the overtemperature controller has not yet been set as required, set it and activate it according to the instructions in the appropriate manual.

Unless a time switch is fitted and is off, the furnace starts to heat up. The Heat light glows steadily at first and then flashes as the furnace approaches the desired temperature or a program setpoint.

Overtemperature option only. If the overtemperature trip operates then an indicator in the overtemperature controller flashes, and the heating elements are isolated. Find and correct the cause before resetting the overtemperature controller according the instructions supplied.

To turn the furnace off, set the Instrument switch to it's off position; the controller display will go blank. If the furnace is to be left off unattended, isolate it the electrical supply.



In models where the fan is subject to the instrument switch, do not switch this off unless the furnace temperature is below 400°C (to initiate cooling, lower the controller setpoint). Failure to observe this may reduce fan motor life

3.2 General Operating Advice

Heating element life is shortened by use at temperatures close to maximum. Do not leave the furnace at high temperature when not required. The maximum temperature is shown on the furnace rating label and on the back page of this manual.

When heating materials which produce smoke or fumes, the chimney must be correctly fitted and unobstructed. Otherwise, soot can accumulate in the chamber and could possibly cause an electrical breakdown of the heating element.

If the furnace is used to heat materials which emit smoke or fumes, regularly heat it up to maximum temperature for one hour without load to burn away the soot.

3.3 Atmospheres

When an optional gas inlet is fitted there is a label near the inlet saying "INERT GAS ONLY". In practice *inert* or *oxidising* gases may be used, but not combustible or toxic gases. Chamber furnaces are not gas tight, so it should be understood that gas usage may be high, and that the chamber is likely always to contain some air. Residual oxygen levels of 1% are to be expected.

3.4 Operator Safety

The furnace has mineral insulated heating elements, and does not require a door safety switch.

Avoid burns. Lenton can supply tongs, face masks, and heat resistant gloves. Before you remove a hot object from the furnace make sure you have a safe place to put it down.

4.0 MAINTENANCE

4.1 General Maintenance

No routine maintenance is required other than removal of soot deposits mentioned in 3.2 and the occasional replacement of consumable items.

The furnace outer surface may be cleaned with a damp cloth. Do not allow water to enter the interior of the case or chamber. Do not clean with organic solvents.

4.2 Calibration

After prolonged use the controller and/or thermocouple could require recalibration. This would be important for processes which require accurate temperature readings or which use the furnace close to its maximum temperature. A quick check using an independent thermocouple and temperature indicator should be made from time to time to determine whether full calibration is required. Lenton can supply these items.

Depending on the controller, the controller manual may contain calibration instructions.

4.3 After Sales Service

Lenton's service division (Thermal Engineering Services) has a team of Service Engineers capable of repair, calibration and preventive maintenance of furnace and oven products at our customers' premises throughout the world. We also sell spares by mail order. A telephone call or fax often enables a fault to be diagnosed and the necessary spare part despatched.

Each furnace has its own record card at Lenton. In all correspondence please quote the serial number, model type and voltage given on the rating label of the furnace. The serial number and model type are also given on the front of this booklet when supplied with a furnace.

To contact Thermal Engineering Services or Lenton see the back page of this manual.

4.4 Recommended Spares Kits

Lenton can supply individual spares, or a kit of the items most likely to be required. Ordering a kit in advance can save time in the event of a breakdown. When ordering spares please quote the model details as requested above.

4.5 Power Adjustment

The furnace control system incorporates electronic power limiting, but in these models the power limit is set to 100% (but see section 8.2 for any exceptions).

Occasionally the power limit is set to zero to permit demonstration of the controls without the heating elements taking power. In this case the power limit may be reset to its standard value to re-enable heating.

The power limit may not be accessible to the operator, in which case, if it is necessary to alter the limit, Lenton can assist with instructions.

5.0 REPAIRS & REPLACEMENTS

5.1 Safety Warning – Disconnection from Supply

Always ensure that the furnace is disconnected from the supply before repair work is carried out.



5.2 Safety Note - Refractory Fibrous Insulation

This furnace contains refractory fibres in its thermal insulation. These materials may be in the form of fibre blanket or felt, vacuum formed board or shapes, mineral wool slab or loose fill fibre.



Normal use of the furnace does not result in any significant level of airborne dust from these materials, but much higher levels may be encountered during maintenance or repair.

Whilst there is no evidence of any long term health hazards, we strongly recommend that safety precautions are taken whenever the materials are handled.

Exposure to dust from fibre which has been used at high temperatures may cause respiratory disease.

When handling fibre always use an approved mask, eye protection, gloves and long sleeved clothing.

Avoid breaking up waste material. Dispose of waste fibre in sealed containers.

After handling rinse exposed skin with water before washing gently with soap (not detergent). Wash work clothing separately.

Before commencing any major repairs we recommend reference to the European Ceramic Fibre Industry Association Bulletin No. 11 and the UK Health and Safety Executive Guidance Note EH46.

We can provide further information on request. Alternatively our service division can quote for any repairs to be carried out at your premises or ours.

1.3 Temperature Controller Replacement

2216, 2416, 2408 etc. Ease apart the two lugs at the side; grip the instrument and withdraw it from its sleeve; push in the replacement.

5.3 Solid-state Relay Replacement

Disconnect the furnace from the supply and remove the furnace back panel.

Make a note how the wires are connected to the solid state relay, and disconnect them. Remove the solid state relay from the base panel or aluminium plate.

Replace and reconnect the solid state relay ensuring that the heat-conducting thermal pad is sandwiched between the relay and the base panel or aluminium plate. Alternatively a thin layer of white, heat-conducting silicon paste may be applied between the new relay and the plate.

Replace the removed panel.

5.4 **Thermocouple Replacement**

Disconnect the furnace from the supply, and remove the furnace back panel.

Make a note of the thermocouple connections. The negative leg of the thermocouple is marked blue. Compensating cable colour codings are:

<i>Negative</i>	<i>positive (type K)</i>
White	green

Disconnect the thermocouple from its terminal block.

Re-assemble with a new thermocouple observing the colour coding, ensuring that the any porcelain spacers are replaced.

5.5 **Element Replacement**



See section 5.2- wearing a face mask is recommended.

The mineral insulated type of element consists of a resistance wire which is centred in a metal tube by a compressed powder. Such elements may be bent into "U" or other shapes without losing the electrical insulation.

Disconnect the furnace from the supply. Remove the furnace back panel.

Carefully note how the elements are connected, and remove the electrical leads from them. Also disconnect the earth (ground) wire from the back of the metal chamber liner.

Unscrew the gland caps on the faulty element, and carefully prise open the split compression collars, which should be retained for fitting to the new element.

Remove the chimney if fitted.

Open the furnace door and slide out the chamber liner.

Withdraw the element through the front of the furnace.

Insert the new element through the glands and refit the compression collars. Their centres should be approximately 40 mm from the end of the element. Firmly tighten the gland cap, ensuring the element lies centrally between the chamber liner and the insulation.

Reconnect the electrical leads, refit the chamber liner and reconnect the earth wire.

Refit the back panel and reconnect the supply.

Check that the furnace is controlling properly to rule out the possibility that previous element failed because of a fault elsewhere in the control circuit.

5.6 **Fuse Replacement**

Fuses are marked on the circuit diagram (section 7.0) with type codes, e.g. F1, F2. A list of the correct fuses is given in section 8.1.

If any fuse has failed, it is advisable for an electrician to check the internal circuits.

Replace any failed fuses with the correct type. For safety reasons do not fit larger capacity fuses without first consulting Lenton.

The fuses are near the cable entry point, and access is by removal of the back panel.

6.0 FAULT ANALYSIS

A. Furnace Does Not Heat Up

- | | | | |
|----|-------------------------------------|--|--|
| 1. | The HEAT light is ON | → The heating element has failed | → Check also that the SSR is working correctly |
| 2. | The HEAT light is OFF | The controller shows a very high temperature or a code such as S.br | → The thermocouple has broken or has a wiring fault |
| | | The controller shows a low temperature | → The door switch(es) (if fitted) may be faulty or need adjustment
<i>not normally applicable to ARF</i> |
| | | | → The contactor (if fitted) may be faulty |
| | | | → The SSR could be failing to switch on due to internal failure, faulty logic wiring from the controller, or faulty controller |
| | | There are no lights glowing on the controller | → The SUPPLY light is ON → The controller may be faulty or not receiving a supply due to a faulty switch or a wiring fault |
| | | | → The SUPPLY light is OFF → Check the supply fuses and any fuses in the furnace control compartment |

B. Furnace Overheats

- | | | | |
|----|---|---|--|
| 1. | The HEAT light goes OFF with the instrument switch | → The controller shows a very high temperature | → The controller is faulty |
| | | → The controller shows a low temperature | → The thermocouple may have been shorted out or may have been moved out of the heating chamber |
| | | | → The thermocouple may be mounted the wrong way round |
| | | | → The controller may be faulty |
| 2. | The HEAT light does not go off with the instrument switch | → The SSR has failed "ON" | → Check for an accidental wiring fault which could have overloaded the SSR |

7.0 CIRCUIT DIAGRAMS

7.1 Single phase

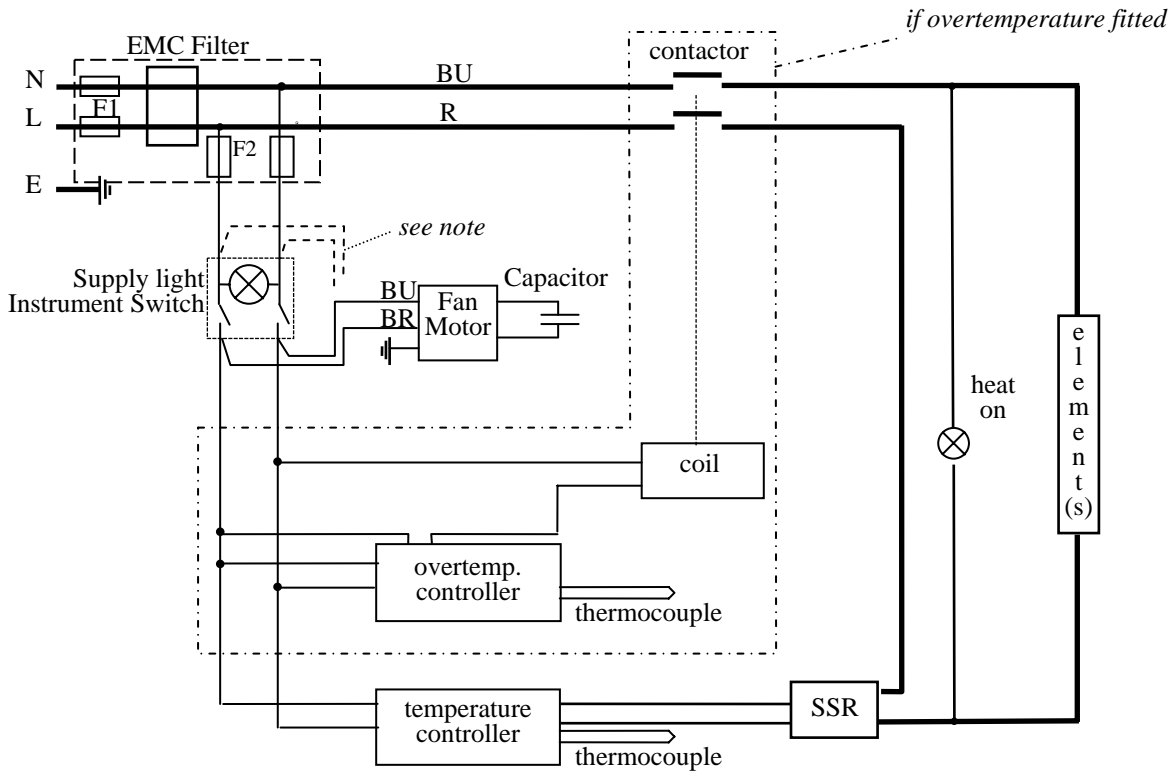

note: In models made before late 2003 the fan was connected to the live side of the Instrument switch. In later models the fan is connected to the switched side of the Instrument switch.

7.2 Higher Voltages

For 254V (or above) an isolating transformer is fitted in the control circuit after the F2 fuses.

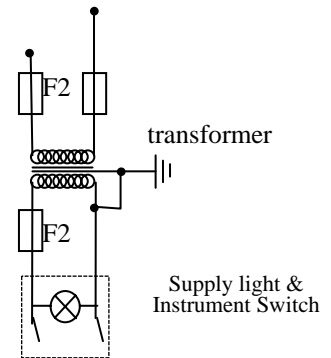

7.3 3-phase “universal” wiring

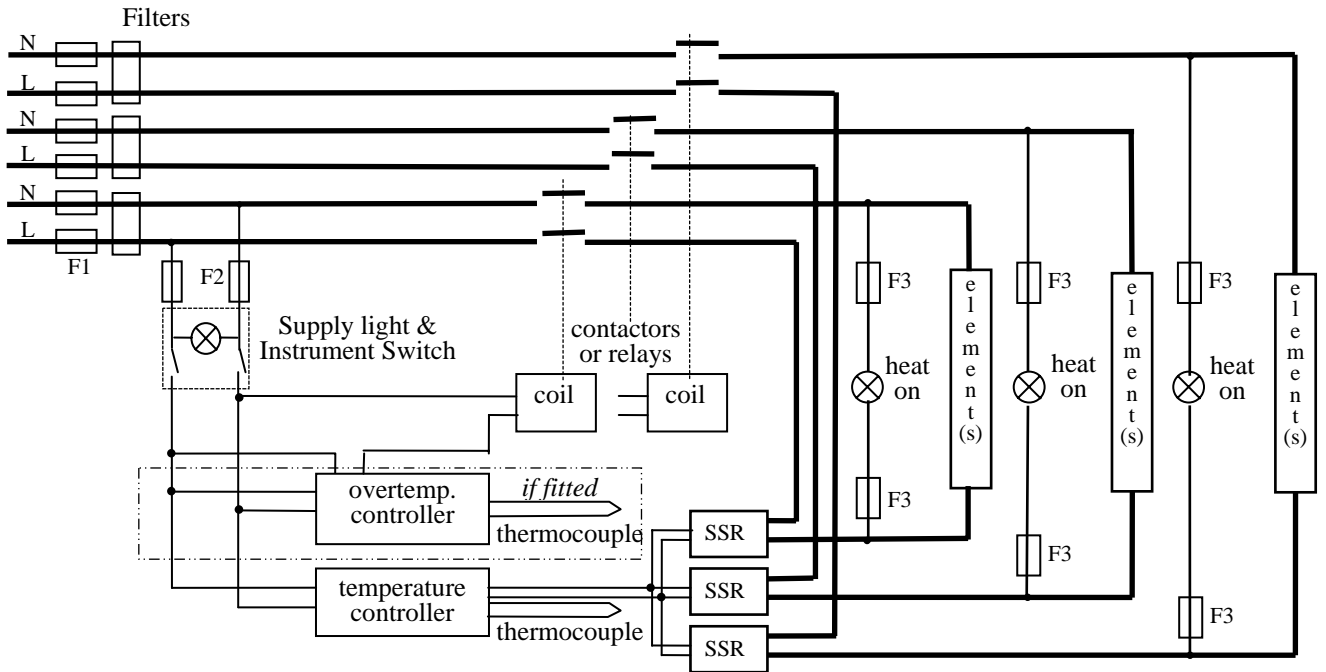

Fuses F1 are always present in this wiring design.
 Fuses F2 could be absent in some circumstances, if the circuit does not exceed 10A.
 Fuses F3 are present if the circuit exceeds 25A, but otherwise are usually absent.

3-phase + neutral

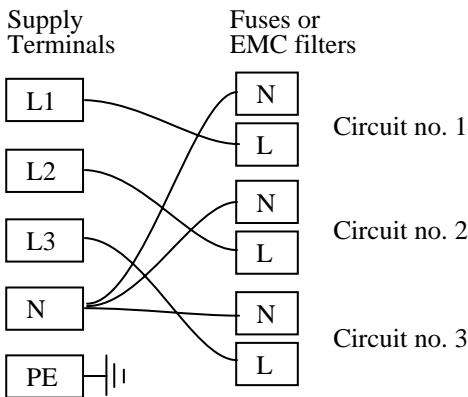

3-phase delta

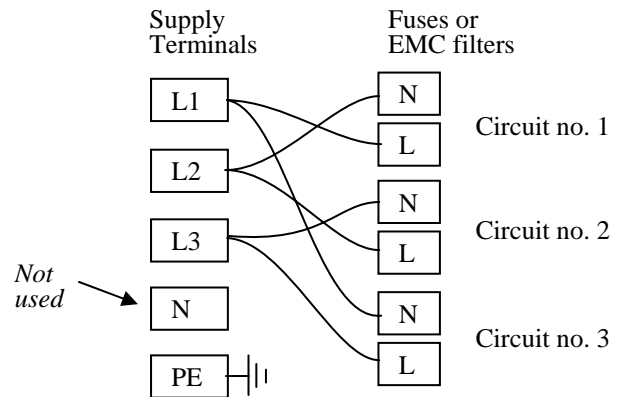

1-phase

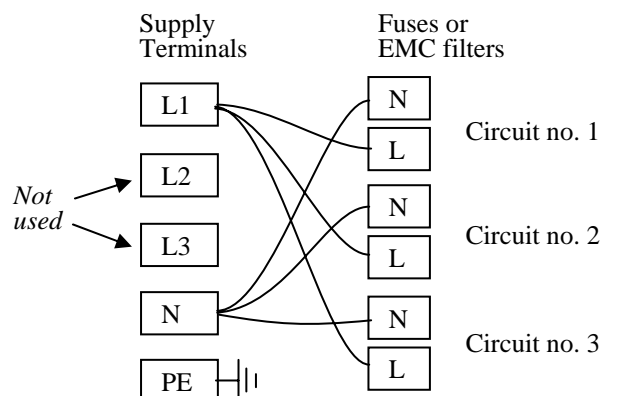

A model made to this diagram can be converted by the customer between the following supply voltages:
 between 3-phase + neutral in the range 380/220V – 415/240V
 and 3-phase delta in the range 220V – 240V
 and single phase in the range 220V – 240V

8.0 FUSES & POWER SETTINGS

8.1 Fuses

F1-F2: Refer to the circuit diagrams.

<i>F1</i>	Internal supply fuses	Fitted if supply cable fitted. Fitted on board to some types of EMC filter.	on-board and up to 16 Amps: 32mm x 6mm type F <i>later models: 38mm x 10mm</i> other: GEC Safeclip or Ferraz to suit supply rating
<i>F2</i>	Auxiliary circuit fuses	Fitted on board to some types of EMC filter.	2 Amps glass type F On board: 20mm x 5mm Other: 32mm x 6mm
	Customer fuses	Required if no supply cable fitted. Recommended if cable fitted.	See rating label for amperage; see table below for fuse rating.

Model	phases	Volts	Supply Fuse Rating
ARF 7/22	1-phase	220-240	15A or 16A
ARF 7/22	1-phase	200-208	15A or 16A
ARF 7/45	1-phase	220-240	30A or 32A
ARF 7/45	3-phase+N	380/220-415/240	10A/ph
ATF 7/45	3-phase delta	220-240	16A/ph

8.2 Power Settings

For models made for 254 volts or 440 volts the power limit parameter $\square PH_i$ may be set to 89%. If in doubt please contact Lenton.

For all other models in this manual the power limit parameter $\square PH_i$ is set to 100%.

9.0 SPECIFICATIONS

Lenton reserves the right to change specifications without notice.

9.1 Models Covered by this Manual

MODEL	Max. Temp. (°C)	Max. Power (kW)	Chamber Size (mm)			Approx. Capacity (l)	Net Weight (kg)
			H	W	D		
<i>Recirculating Air Furnace heated by mineral insulated elements.</i>							
ARF 7/22	750°C	3.0	220	200	495	22	55
ARF 7/45	750°C	6.0	295	265	575	45	

9.2 Environment

The furnaces contain electrical parts and should be stored and used in indoor conditions as follows:

temperature: 5°C - 40°C

relative humidity: maximum 80% up to 31°C decreasing linearly to 50% at 40°C

For preventive maintenance, repair and calibration of all Furnace and Oven products, please contact:

Thermal Engineering Services

Telephone: UK: 0845 3308035 Int: +44 1433 623335
Fax: UK: 0845 3308036 Int: +44 1433 623336
Email: service@thermalservice.com



Lenton

LF05-1.21 18/09/08

Lenton
PO Box 2031
Hope Valley
S33 6BW
Tel: (+44) (0) 1433 621515
Fax: (+44) (0) 1433 623600
Email: sales@lentonfurnaces.com